

Wide belt sanding machines

**WEBER 600**

**WEBER 1000**

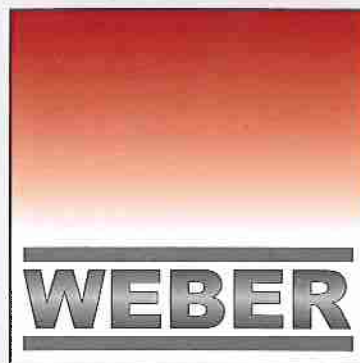

*The future today!*

# WEBER 600 single and two-belt / WEBER 1000

## Standard machine equipment:

- Grooved steel contact roller
- Pneumatic roller lift
- Sanding belt grit compensation with roller adjustment
- ISA segmented platen system
- Work piece detection 22 mm sensors
- Universal lamella for sanding veneer and solid wood
- Segmented platen controlled by feed
- Adjustable sanding pressure
- Tolerance compensation +/- 1 mm
- Tracking controlled by precise, rugged detection sensor
- Belt run-off switches
- Two feed speeds for calibration and finish-sanding
- Table extension with rollers at the infeed and outfeed
- Safety equipment meeting CE standard

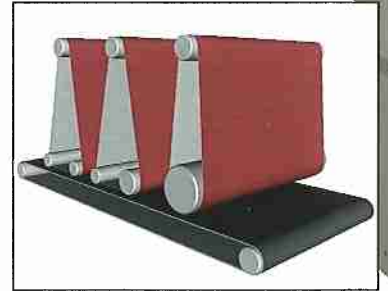
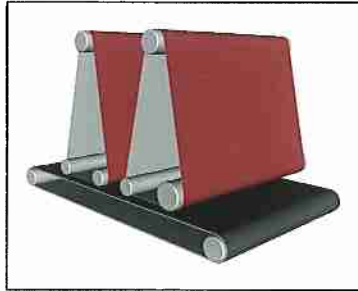
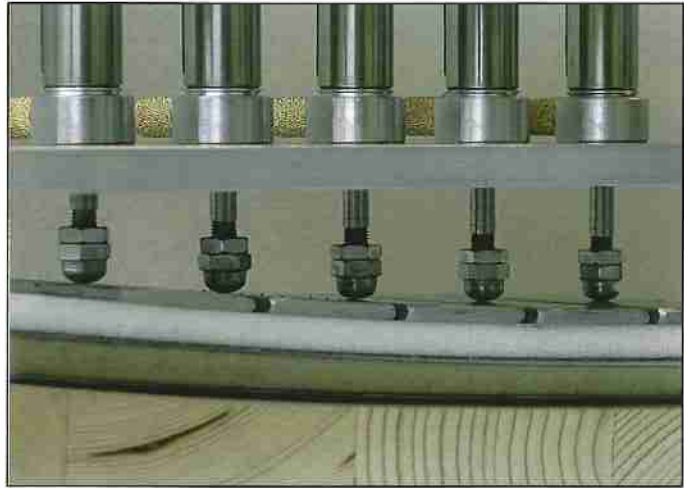
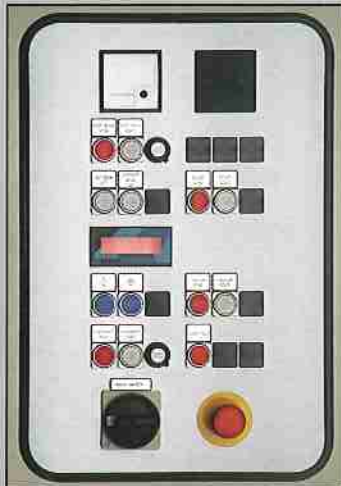

## WEBER 600 and 1000

### – Optional convenience package:

- Touch screen with program memory
- Automatic thickness setting
- Infinitely adjustable feed

## WEBER 1000

### – Optional lacquer package:

- Infinitely adjustable sanding belt speed
- Sanding belt cleaning blow off
- Vacuum conveyor

## WEBER 1000 – additional options:

- Cleaning brush or Scotchbrite roller

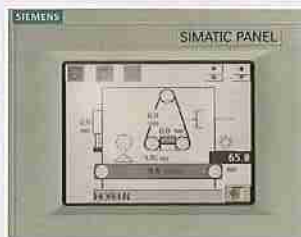

Touch panel

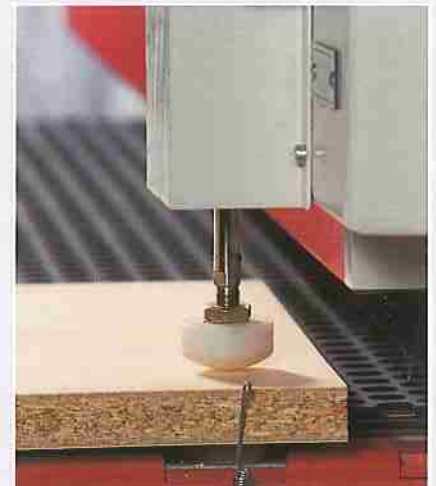

Automatic thickness measurement

# single, two and three-belt sanding machines



## WEBER Intention –

– a version to meet all requirements, complete with convenience and lacquer package.

**WEBER**   
– the solution

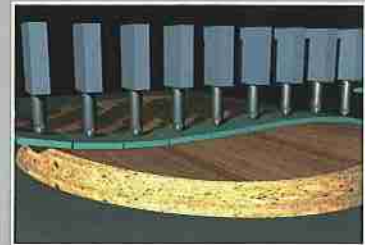

- Patented segmented platen version
- Wear and service-free version
- Segments 'float' in the longitudinal and cross direction
- No cross forces to damage the cylinders
- Wear-free mechanism
- Tolerance compensation min. 2 mm
- Universal lamella for all sanding tasks
- Sanding pressure individually adjustable on all edges



Contact roll and segmented platen stations



Freely movable idler roll



Grooved steel contact roll

# The series and its parameters

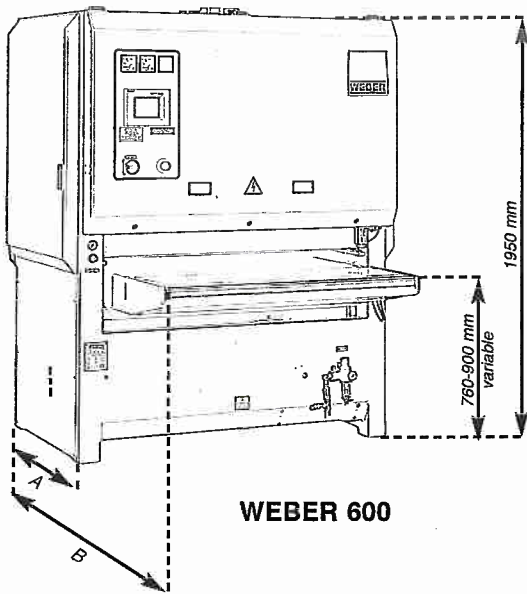

**WEBER 600**

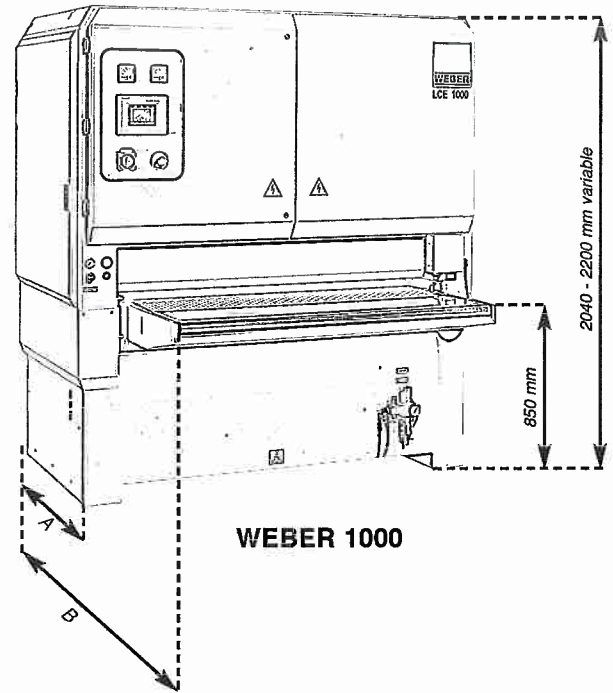

**WEBER 1000**

	WEBER 600		WEBER 1000	
Working width (mm)	1100	1350	1100	1350
Machine width (mm)	1600	1850	1690	1940
Extraction per unit (m <sup>3</sup> /h)	1850	1850	1850	1850
Diameter (mm)	Ø180	Ø180	Ø180	Ø180
Basic machine weight approx.	1,0t	1,1t	1 and 2-belt: 1.2t 3-belt: 1.5t	1 and 2-belt: 1.3t 3-belt: 1.6t
+ weight per unit approx.	0,5t	0,5t	0.5t	0.6t
Wide belt dimensions (mm)	1120 x 1900	1370 x 1900	1120 x 2150	1370 x 2150
Frame length "A"	1 and 2-belt: 870 mm		1 and 2-belt: 1000 mm 3-belt: 1300 mm	
Installation length "B"	1 and 2-belt: 1890 mm		1 and 2-belt: 2190 mm 3-belt: 2490 mm	

All rights for technical modifications withheld.

## Tradition and innovation

### Quality from Upper Franconia

The company, established more than 100 years ago and looking back on a long tradition, has been manufacturing sanding machines from the very beginning. The Weber machine factory guarantees innovative and high quality machine construction.



More than 300 employees work at two production sites.

Hans Weber Corp.  
PO Box 3387  
Olathe, KS 66063-3387  
info@weberamerica.com  
Phone ++1-913-254-1611  
Toll Free ++1-877-519-9795  
Fax ++1-913-254-1582  
www.weberamerica.com

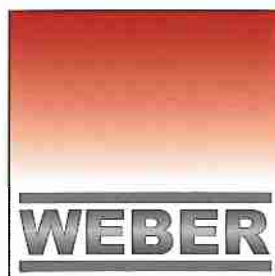

Hans Weber  
Maschinenfabrik GmbH  
Bamberger Str. 19 - 21  
D-96317 Kronach  
Tel. +49 (0) 92 61 409-0  
Fax +49 (0) 92 61 409-399  
email: info@hansweber.de  
www.hansweber.de